



High Quality Usability Dynamic range

All-in-one OTDR

AQ7290 Series

Optical Time Domain Reflectometer



Precision Making

Bulletin AQ7290-01EN

In 2002, Yokogawa Test&Measurement became a leading supplier of optical test and measurement solutions following the acquisition of Ando Electric. An industry pioneer with over 40 years of experience in optoelectronic technology and real world lab and field testing, Yokogawa delivers field test equipment solutions with world renowned quality and exceptional performance. Designed in response to the growing need for reliable and easy-to-use field test instruments for installation and maintenance of fiber optic networks, the Yokogawa Test&Measurement AQ7290 Optical Time Domain Reflectometer (OTDR) Empowers field technicians to confidently Make fast and precise measurements. The AQ7290 OTDR satisfies a broad range of test and measurement needs in research, manufacturing and optical network analysis, from access to core and delivers:

RELIABILITY – The AQ7290’s robust design allows for operation in harsh field conditions and its proven operating system assures stability, prompt response, and superior protection against software virus attacks.

EASE-OF-USE – This instrument boasts dual operation modes through a multi-touch touchscreen and hard-key buttons. It enables fully-automatic measurements and easy-to-read analytic reports through new software applications.

In addition, a new simple OTDR mode is implemented to allow for a wide range of users, from beginners to experts.

SPEED – With lightning-fast startup and immediate reporting via wireless connectivity, this OTDR’s multi-tasking operation maximizes productivity.



1981
AQ-1702



1990
AQ-7140



1998
AQ7250

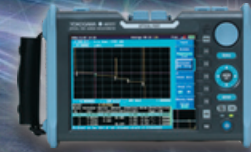

2008
AQ7275

Yokogawa's OTDR technology
for over 40 years



Mid-range
Lineup

2010 Multi Field Tester OTDR
AQ1200 Series



2014
AQ7280



2019 Multi Field Tester OTDR
AQ1210 Series



2025 **New**
High-End model OTDR
AQ7290 Series

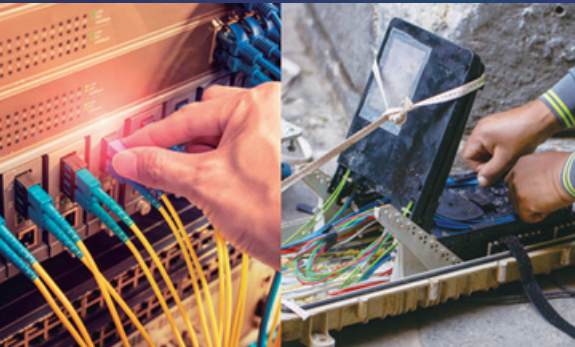

Ease of use for anyone, anywhere

YOKOGAWA All-in-one OTDR

The AQ7290 OTDR offers first-class performance thanks to updated functions, a large capacity battery, and a large user-friendly screen. Additional benefits that ensure measurement quality and improve work efficiency include:

Superior OTDR performance

- Up to 6 OTDR model to choose from
- Improved dynamic range
- Improved event detection performance
- High reflection real time measurement

Pursuit of ease of use

- 8.4-inch high luminance color LCD
- Smartphone-like usability
- Wireless LAN adapter support enables remote control*

*To use this function, a commercially available wireless LAN adapter is required.

Reliable workability

- Multi-fiber measurement up to 2000 fibers
- Auto-execute multiple measurements and analyses with Smart Mapper
- Simple OTDR function for beginners

Much more than an OTDR

- Variety of optional features for multi-tasking
- Application software that supports analysis
- Efficient multi-fiber measurement

Touch panel application menu

The 8.4-inch touchscreen enables intuitive operation. Select the desired function by simply tapping the icon on the main menu.



Function icons in the main menu

USB Type-C power supply

AQ7290 supports power supply from USB Type-C. It does not require a dedicated AC adapter and can be charged by using power adapter* that supports USB power delivery. In addition, It can also be powered from a mobile battery, allowing it to respond to sudden dispatch with ease.

*USB Power delivery 2.0 or later, an adapter with an output of 45 W or more is required. For details, please refer to the specifications page.

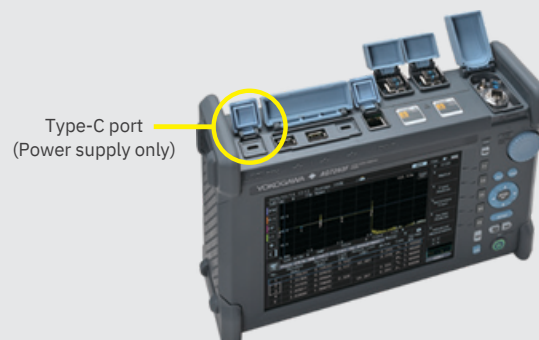



Optical Time Domain Reflectometer

AQ7290 Series

For information on products and firmware updates, please visit

<https://tmi.yokogawa.com/p/eq7290/>



Remote control

By using a commercially available wireless LAN adapter and Wi-F router, OTDRs can be operated remotely. This allows users to operate and check OTDRs in the field from the office or home, it is ideal for business support by veterans and saving labors.



Work in the field can be checked from the office or home

Simple OTDR for easy measurement

The AQ7290 has a new “Simple OTDR” function. A simple screen allows for setup and measurement, a pop-up window assists on saving and other tasks after measurement.



Start measurement with a single button from the settings screen

Full range of selection

The AQ7290 series is an integrated OTDR with a choice of 6 OTDRs and 2 OPMs depending on wavelength and application.

It meets a wide range of needs from FTTH installation and maintenance to long distance measurement over 100 km.



Yokogawa OTDR model map

Model	Num. of λ	Num. of port	Dynamic range (dB)				Features
			Port 1 (nm)			Port 2 (nm)	
			1310	1550	1625	1650	
AQ7292A	2	1	37	35			Short range model up to 70 km with communication service wavelength.
AQ7293A	2	1	41	40			Equipped with communication wavelengths and includes a splitter with no more than 128 branches Standard model ideal for networks.
AQ7294A	2	1	45	45			High DR model equipped with communication wavelength and suitable for long distance measurement over 100 km.
AQ7293F	3	2	41	40		38*	2-port 3-wavelength model ideal for maintenance of working lines with 1650 nm with built-in optical filter.
AQ7293H	3	1	41	40	38		1-port 3-wavelength standard model with 1625 nm in addition to communication wavelength
AQ7294H	3	1	45	45	43		1-port 3-wavelength High DR model with 1625 nm in addition to communication wavelength

*A built-in cut filter to isolate from communication wavelengths included

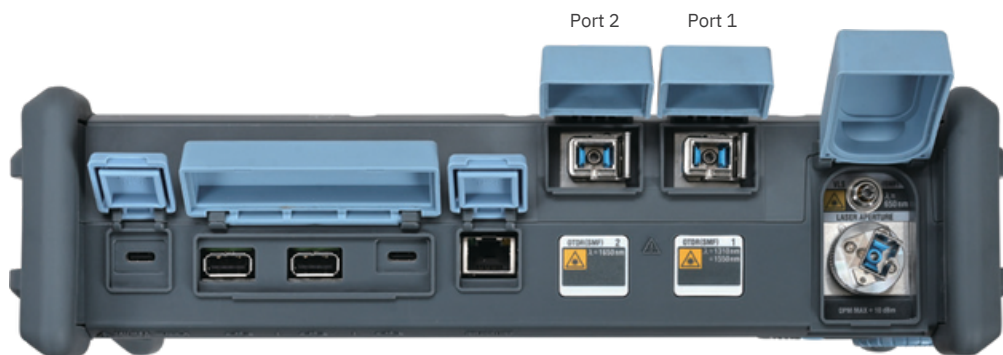

Superior OTDR performance

Improved Dynamic range

In OTDR measurement, dynamic range is one of the most important factors to indicate the distance that can be measured. The AQ7290 has improved the dynamic range by 1 to 3 db at all wavelengths compared to the previous model (AQ7280). This enables measurement of longer distances that could not be seen before.

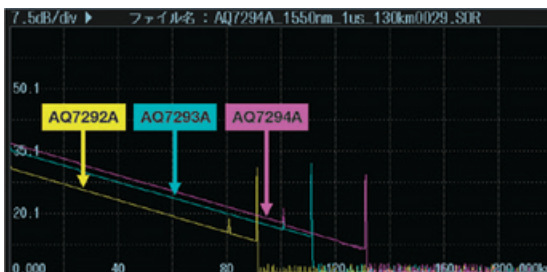

Improved event detection performance

The AQ7290 also offers improved event detection performance. An event dead zone of 0.6 m or less and an attenuation dead zone of 2.5 m or less have been achieved, enabling separation of events closer together. It is possible to detect connector connection points that are close to each other, such as indoor and in-station wiring.

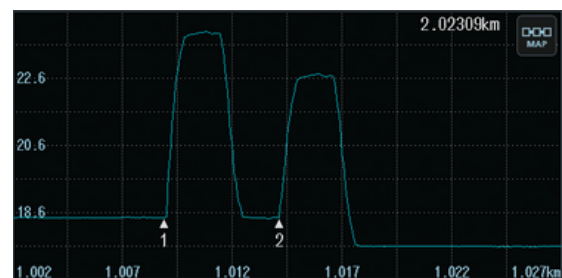
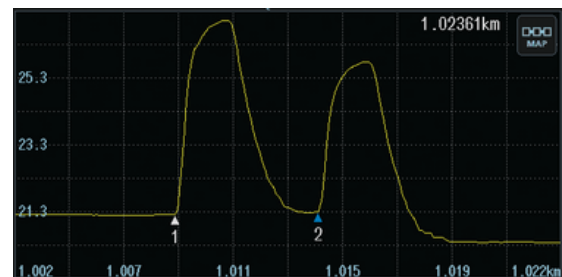

Yellow: AQ7280
Blue: AQ7290

High reflection real time measurement

In real-time measurement, the quality of the displayed waveform is emphasized and updated while displaying the waveform with high accuracy. It is possible to measure the far end of long-distance routes and multi-branch splitters, which have been invisible in conventional real-time measurements.



Yellow: Realtime (High-Reflection)
Blue: Realtime (High-speed)

PON measurement performance

The AQ7290 also offers improved PON measurement performance. Up to 128 branches are supported.

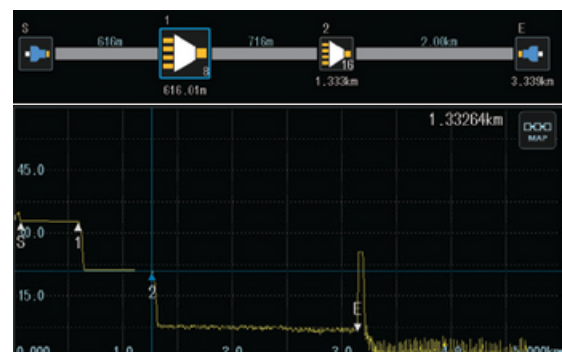

Measurement example of 128-branch splitter

Pursuit of ease of use

Multi-tasking

Functions other than OTDR can be used at the same time by activating them from the OTDR measurement screen. This unique multi-tasking feature reduces measurement idle time and revolutionizes the test process by enabling simultaneous parallel testing instead of serial testing. Multi-tasking features include Stabilized light source, visible light source, power checker, optical power meter, fiber surface image display, and optical switch box are available for multi-tasking.

*The stabilized light source and power checker cannot be used simultaneously with the OTDR.
Fiber inspection probe surface display and optical switch box cannot be used at the same time.

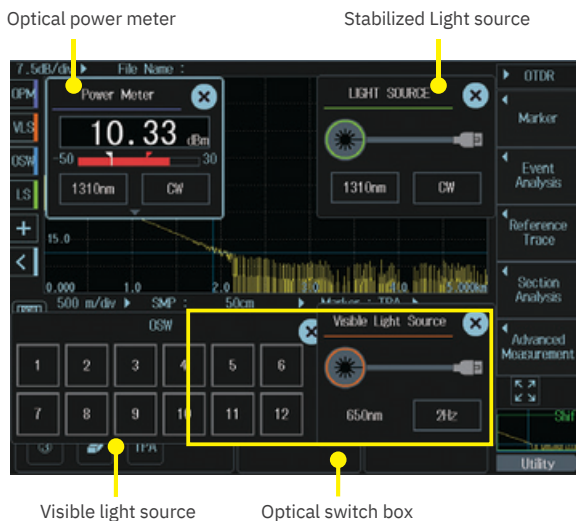

Multi-language support

The AQ7290 OTDR series offers users multiple display languages including but not limited to: Chinese, Czech, Dutch, English, Finnish, French, German, Italian, Norwegian, Polish, Portuguese, Spanish, Swedish, and Turkish.

Multi-touch capacitive touchscreen

The intuitive multi-touch setup enables operations like pinch zooms and drag, similar to a smartphone or tablet.

*The touchscreen feature can be disabled for users who prefer the hardware key operations

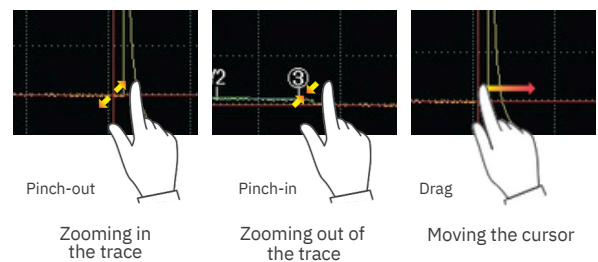

Up to 60000 waveforms can be stored in the int. memory.

The AQ7290 is equipped with 1 GB of internal memory. Up to 60000 waveforms can be stored, allowing work to be performed with confidence even when large amounts of data need to be stored, such as in multi-fiber measurements. Memory expansion with SD cards is also supported, allowing storage of up to 2 TB.

File transfer

File transfers can be performed using USB, Ethernet cables, or wireless LAN adapters. Also offer Data Transfer, software that enable data transfer between OTDRs and mobile devices. Using it, file in the OTDR can be saved to cloud storage or be attached to an email by mobile device connected to the AQ7290 with wireless LAN. And also allows for simple analysis of the loaded waveforms.

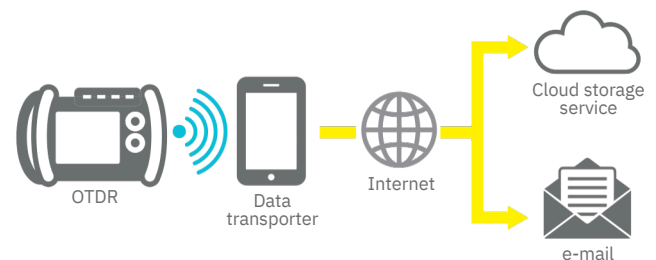

Wireless remote control

The AQ7290 can be connected to an external terminal via a wireless LAN adapter. OTDRs within wireless LAN range can be controlled from external terminals, exchanged measurement data, and used wireless LAN-compatible fiber optic inspection probes.

Advantages of remote control?

Conventional OTDRs require one worker on the building and one at the work site, which requires waiting time and communication between workers. By controlling OTDRs remotely, it is possible to operate OTDRs installed at the building beforehand from the work site, leading to reduced man-hours and increased work efficiency. In addition, since OTDRs can be operated from the office or home, it also contributes to remote response to sudden troubles and training of technicians.

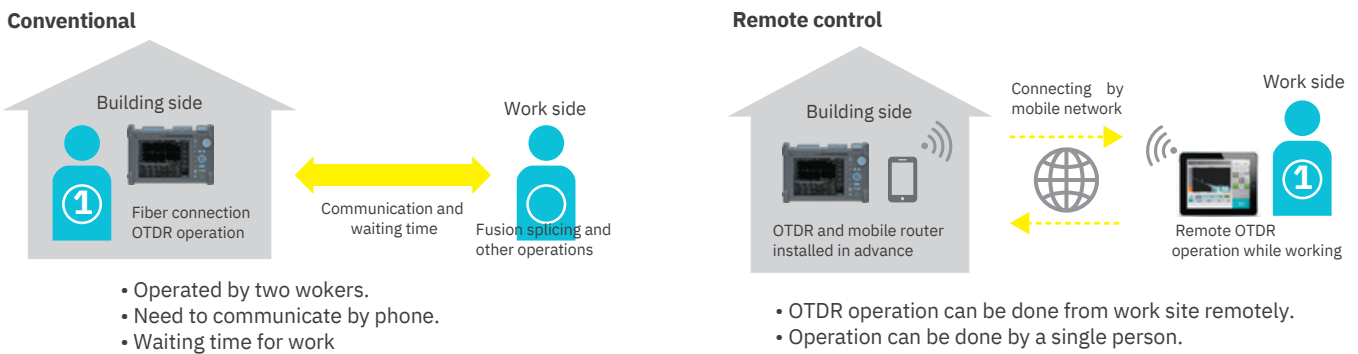

Remote control from WEB browser

“The remote control function can be used from either a web browser or the AQ7933 remote controller. When controlling from a web browser, there are no OS restrictions. It can be accessed from both smartphones and PCs. By entering the IP address and password in the browser’s address bar, you will be directed to the control screen. The control screen uses the same GUI as the OTDR, allowing you to operate it just like the actual device.”



Reliable workability

Multi-fiber Measurement



A project file is created that defines the test conditions of each fiber, with the measured data managed in a fiber number table. From here, the fiber is selected to perform tests, and once these are completed, the fiber number color changes to help prevent omission and confusion.



Create a table having the same configuration as an optical termination box (up to 2000 fibers)
Save the data with the same number as the fiber number

AQ3550 Optical Switch Box

Multi-fiber measurement can be linked with the AQ3550 optical switch box. By linking with the AQ3550, numbers are displayed at the top of the created project, allowing the user to immediately check the core wire and number under measurement.



Simple OTDR



This feature allows you to easily perform OTDR measurements with a single button. Measurements are conducted according to pre-set conditions. There is no need for complex settings or operations, and after the measurement, a pop-up clearly indicates the next steps. This makes it easy for operators who are not familiar with using OTDR to use it with confidence.



Schedule Measurement (Monitoring function)



OTDR measurements are automatically performed based on user-defined intervals to detect network connection interruptions caused by intermittent events. The dB value of a fixed point and the loss over a specific section are displayed in the logging view to check changes over time. Saved trace data and logging graph data can be analyzed later.

*MNT option of the OTDR main frame is required

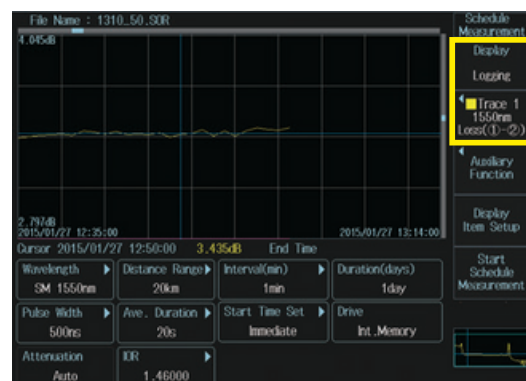

Smart mapper



With Smart Mapper, users can press a single button to execute measurements, detect network events, and perform PASS/FAIL judgments. It includes a simple icon-based map view for easy interpretation of location and types of events, so even beginners can understand complex network configurations. PASS/FAIL judgments for each event are performed automatically based on thresholds specified in advance.

Measuring a network from the station to antenna

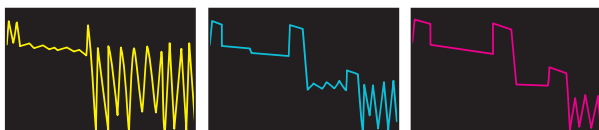
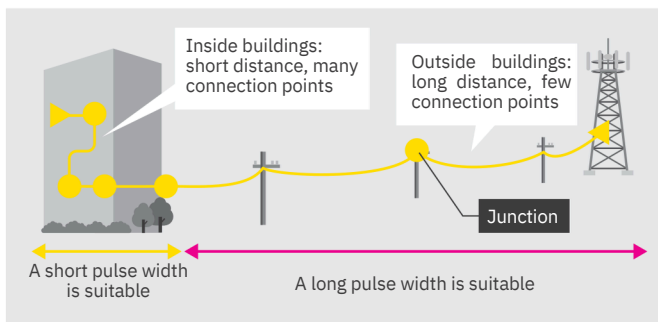

Short pulse width Medium pulse width Long pulse width

↓ Takes certain parts of the measured traces, links trace together

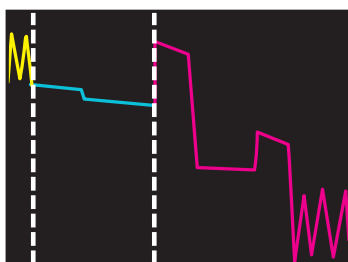

↓ Event analysis

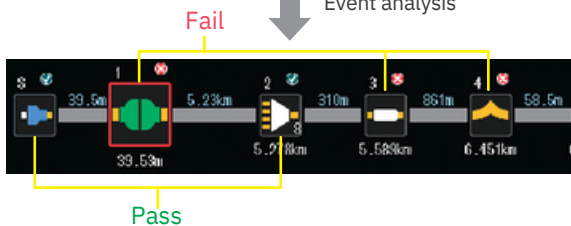

Event icon

The appropriate icon will be displayed from 5 different event icons.

PASS/FAIL judgment results can be easily recognized by the “✓” and “×” marks and colors.

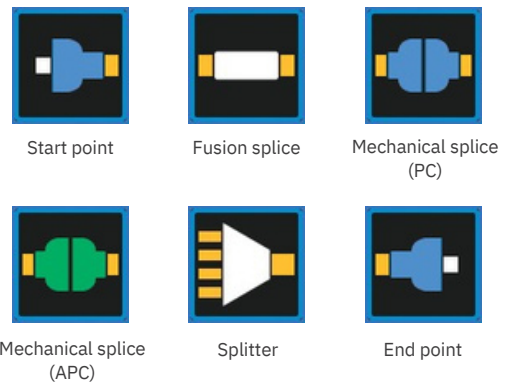

Advanced trace analysis



The OTDR main unit enables advanced analysis of measurement data

Type	Evaluation target
Multi-trace analysis	Multi-fiber cables
2-way trace analysis	Connection points with different loss values measured from both directions
Differential trace analysis	Aged deterioration of fibers

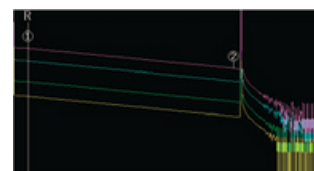

Multi-trace analysis

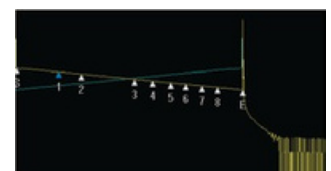

2-way trace analysis

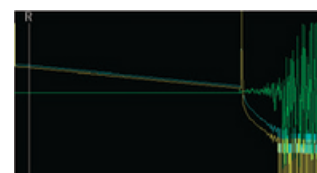

Differential trace analysis

Much more than an OTDR

Various functions required for optical fiber installation and maintenance work

Measurement functions required for optical fiber installation, replacement and maintenance can be installed on the OTDR. They are available for single-tasking and multi-tasking.

Stabilized Light source

(Standard feature)



Light source feature using the OTDR port. It can be used as a light source for core control and for loss measurement. It is also possible to modulate OTDR wavelengths.

Modulation modes (1310, 1550, 1625, 1650 nm)

CW	270 Hz	1 kHz	2 kHz
----	--------	-------	-------

Visible Light Source (/VLS option)



Using a visible and continuous/modulated red light laser is an invaluable test option that checks the continuity of patch cords, launch fibers, and short fiber trunks. Breaks and bends in the fiber can easily be identified through visual inspection, as the visible light exits the fiber at the fault events. And since this feature uses a separate port from OTDR/OPM, another fiber is searchable while the OTDR/OPM is in use, which improves work efficiency. A flashing light emission is also available.

Optical Power Meter



Loss measurement is possible in combination with a stabilized light source. A high-power type is also available for a wide range of applications.

Option	/SPM	/HPM	800 nm to
Wavelength Settings	800 nm to 1700 nm	1700 nm	+27 to
Power range (CW)	+10 to -70 dBm	-50 dBm*	+24 to
Power range (CHOP)	+7 to -70 dBm	-50 dBm*	

*In the wavelength range of 1300-1600 nm

AQ7933 OTDR Emulation software

The AQ7933 emulation software displays and analyzes trace data measured on an OTDR and creates and outputs analysis reports via PC. Users can upload up to 1000 trace sand the SOR software function sets events or markers on all loaded traces collectively. The software also includes remote control and file transfer functions, allowing the user to perform many functions from OTDR operation, analysis, report creation and transfer, and more.

*The AQ7933 can be downloaded from the YMI website. We offer a trial version of the software, in which

all the functions are available for free for a trial period.

For information on products, please visit: https://tmi.yokogawa.com/p/p_aq7933/

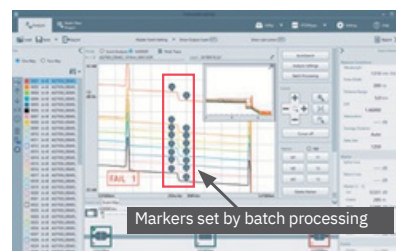

Power Checker (/PC option)



This is a simple optical power measurement function using the OTDR port. Continuous measurement of optical power and OTDR is possible without replacing optical fibers.

Fiber Inspection Probe

Fiber surface image display (standard feature)



Scratches and dirt on a fiber connector's surface can cause communication network failures, optical fiber deterioration, and can significantly affect OTDR measurement results. A video fiber inspection probe* enables visualization of a fiber connector's surface for inspection of defects.

For information of Verified Products, please visit: <https://tmi.yokogawa.com/p/otdr/>



Fiber surface test function (option)

This feature automatically analyzes scratches and dirt on the fiber's surface and makes a PASS/FAIL judgment based on either IEC 61300-3-35-compatible criteria or other decision criteria dictated by the user. The surface image and judgment results are savable and available as PDF reports.

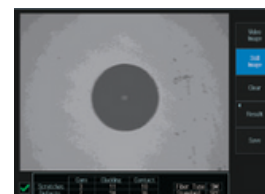

*/FST option and a recommended optical fiber inspection probe are required
*This feature is not available for multi-tasking

Specifications

AQ7290 General Specification

Note. All specifications are valid at 23°C±2°C, unless otherwise specified.

Items	Specification		
Display*1	8.4-inch color TFT LCD (Resolution: 800 × 600, Multi-touch capacitive touchscreen)		
Electrical interface	USB 2.0 × 3 (Type-A (Host) × 2, Type-C × 1)*2 Ethernet (1000BASE-T) × 1 (Option), microSD card slot × 1		
Remote control	USB 2.0 Type-C, Ethernet (Option)		
Data storage	Storage	Internal: 1 GB, ≥60,000 traces Internal expansion: microSD memory card External: USB memory	
	File format	Write: SOR, SOZ, CSV, SET, SMP, BMP, JPG, PDF Read: SOR, SOZ, SET, SMP	
Dimensions	Approx. 287 mm (W) × 210 mm (H) × 80 mm (D) (excluding projections)		
Weight	Approx. 2.6 kg (including internal battery and protectors)		
OTDR functions	Minimum redout resolution	Horizontal axis: 1 cm, vertical axis: 0.001 dB	
	Group	1.30000 to 1.79999 (0.00001 intervals)	
	Distance unit	m, km (others)	
	Distance measurement accuracy	±(0.75 m + measured distance × 2 × 10 ⁻⁵ + sampling resolution)	
	Measurement	Distance, Loss, Return loss, Section Return loss, dB/km	
	Analysis	Multi trace analysis, Two-way trace analysis, Differential trace analysis, Distance trace analysis, Macro bending	
	Others	Multi-fiber project, Rerouted fiber comparison, Work completion notice, Remote control, File report. Auto event search, Pass/Fail judgement, web server, Auto loss test, Plug check, Fiber-in-use alarm, Optical switch box control, Fiber surface test (Option), Schedule measurement (Option), Smart mapper	
Environment conditions	Operating	Temperature	-10 to 50°C
		Humidity	≤95% RH (non-condensing)
	Storage	Temperature	-20 to 60°C
		Humidity	≤95% RH (non-condensing)
	Altitude	4000 m	
Power requirements	USB power supply (Type-C) USB Power Delivery Revision 2.0 or later, ≥45 W (Power supply only), DC 15 V±5%, max. 3 A		
Battery	Type	Lithium-ion	
	Operating time*3	15 hours (Telcordia GR-196-CORE Issue2 2010)	
	Charging time*3	6 hours	
EMC	Emission	EN 61326-1 Class A, EN 55011 Class A Group1	
	Immunity	EN 61326-1 Table2	
Safety*4	Laser	EN 61010-1, EN 60825-1: 2014+A11: 2021 IEC 60825-1: 2014 FDA 21 CFR 1040.10 GB/T 7247.1-2024	

*1 The LCD may contain some pixels that are always ON or OFF (0.002% or fewer of all displayed pixels including RGB), but this is not indicative of a general malfunction.

*2 USB Type-A is for external memory, fiber inspection probe and optical switch box. USB Type-C is for remote control and internal storage access with a PC.

*3 Typical

*4 When mounted with power meter and visible light source

*5 Laser safety

IF VLS OPTION IS AVAILABLE
安装了 VLS 选项时

VISIBLE LASER RADIATION
AVOID DIRECT EYE EXPOSURE
CLASS 3R LASER PRODUCT
可见激光辐射
避免眼睛受到直接照射
3R类激光产品
(EN 60825-1:2014+A11:2021)
(IEC 60825-1:2014, GB/T 7247.1-2024)
MAX OUTPUT 5mW
WAVELENGTH 650±20nm
PULSE DURATION CW

CLASS 1 LASER PRODUCT
1类激光产品
(EN 60825-1:2014+A11:2021)
(IEC 60825-1:2014, GB/T 7247.1-2024)

Complies with 21 CFR 1040.10 and 1040.11
except for conformance with IEC 60825-1
Ed. 3., as described in Laser Notice No. 56,
dated May 8, 2019.
4-9-8 Myojin-cho, Hachioji-shi,
Tokyo 192-8566, Japan

OTDR

Note. All specifications are valid at 23°C±2°C, unless otherwise specified.

Items		Specifications					
Model		AQ7292A	AQ7293A	AQ7294A	AQ7293F	AQ7293H	AQ7294H
Wavelength (nm) ^{*10}		1310 ±20/ 1550 ±20	1310 ±20/ 1550 ±20	1310 ±20/ 1550 ±20	1310 ±25/ 1550 ±25, 1650 ±5*7	1310 ±20/ 1550 ±20/ 1625 ±25	1310 ±25/ 1550 ±25/ 1625 ±25
Number of optical ports		1			2 (Port 2: 1650 nm, 1 including a filter)		
Applicable fiber		SM (ITU-T G.652)					
Distance range (km)		0.1 to 512					
Pulse Width (ns)		3, 10, 20, 30, 50, 100, 200, 300, 500, 1000, 2000, 5000, 10000, 20000					
Event dead zone*1, *2 (m)		0.6/0.6	0.5/0.5	0.5/0.5	0.5/0.5, 0.5	0.5/0.5/0.5	0.5/0.5/0.5
Attenuation dead zone*1, *3 (m)		3.5/4	2.5/3.5	2.5/3.5	2.5/3.5, 3.5	2.5/3.5/3.5	2.5/3.5/3.5
PON dead zone*1, *4 (m)		35/45	30/40	30/40	30/40, 40	30/40/40	30/40/40
Dynamic range*1, *5 (dB)		39/37	43/42	47/47	43/42, 40	43/42/40	47/47/45
Loss measurement accuracy*6(dB/dB)		±0.03					
Optical return loss measurement accuracy		±2 dB					
Optical connector		Universal adapter SC, FC, and SC Angled-PC					
Laser class		Class 1					
Number of sampling points		Max. 256000					
Sampling resolution		Min. 2 cm					
Maximum optical output power		-			≤+15 dBm (1650 nm)-		
Stabilized Light source	Wavelength (nm)	1310 ±25/ 1550 ±25	1310 ±25/ 1550 ±25	1310 ±25/ 1550 ±25	1310 ±25/ 1550 ±25, 1650 ±5	1310 ±25/ 1550 ±25/ 1625 ±25	1310 ±25/ 1550 ±25/ 1625 ±25
	Optical output power	-3 dBm ±1 dB					
	Output power stability (dB)*8	±0.05/±0.05	±0.05/±0.05	±0.05/±0.05	±0.05/±0.05, ±0.15	±0.05/±0.05/±0.15	±0.05/±0.05/±0.15
	Modulation mode	CW, 270 Hz, 1 kHz, 2 kHz					
	Optical output port	OTDR port					
Laser class		Class 1					

*1 Typical
 *2 Pulse width: 3 ns, Return loss: ≥55 dB, Group refractive index: 1.5, at 1.5 dB below the unsaturated peak level
 *3 Pulse width: 10 ns, Return loss: ≥55 dB, Group refractive index: 1.5, at a point where the backscatter level is within ±0.5 dB of the normal level
 *4 Pulse width: 100 ns (AQ7292A), 50 ns (Other than AQ7292A), non-reflective fiber with a loss of 13 dB.
 *5 Pulse width: 20000 ns, measurement time: 3 minutes, SNR = 1, decrease by 0.5 dB with an angled-PC connector.
 *6 ±0.05 dB for a loss of 1 dB or less
 *7 At 20 dB below the spectral peak of pulsed optical output, at 23 °C, after 30 minutes warm up
 *8 Constant temperature, for 5 minutes after 5 minutes warm up.

Interface

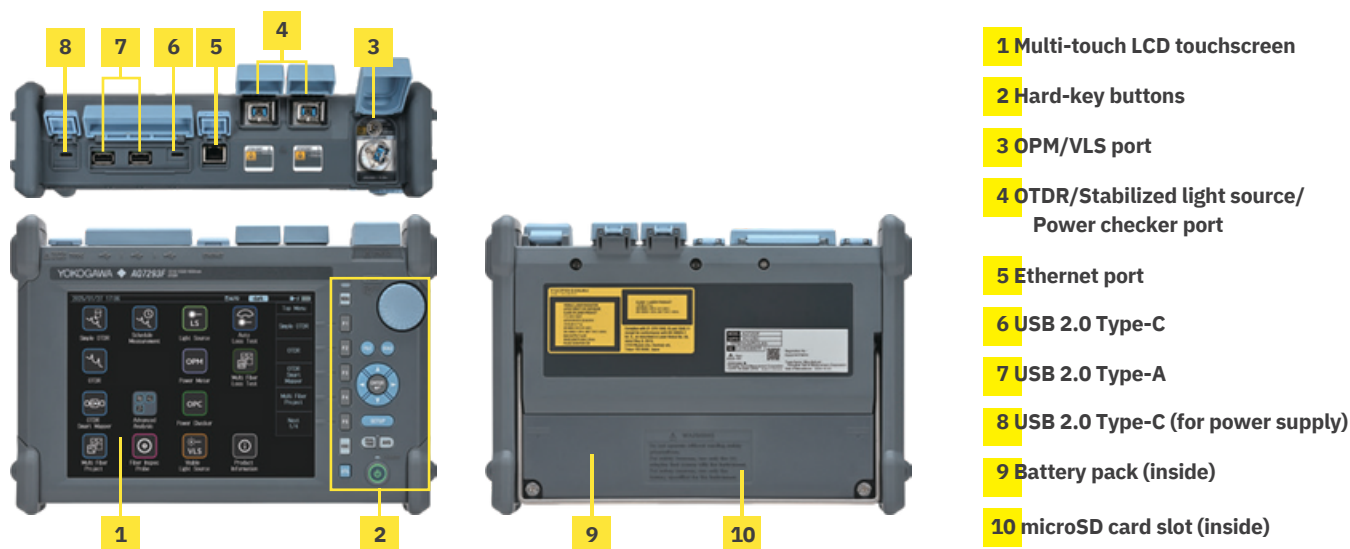

Optical power meter (Option)

Note. All specifications are valid at 23°C±2°C, unless otherwise specified.

Items		Specifications		
Model		Standard power meter (/SPM)	High power (/HPM)	
Optical power meter (OPM)	Wavelength settings	800 to 1700 nm		
	Power range	CW	-70 to +10 dBm	-50 to +27
		CHOP	-70 to +7 dBm	dBm*3 -50 to +27 dBm*3 50
	Noise level	0.5 nW (-63 dBm, 1310 nm)		
	Applicable fiber	SM (ITU-T G.652), GI (50/125) nW (-43 dBm)		
	Uncertainty*1	±5%		
	Readout resolution	0.01 dB		
	Level unit	Absolute: dBm, mW, μW, nW Relative: dB		
	Modulation mode	CW, 270 Hz, 1 kHz, 2 kHz		
	Averaging	1, 10, 50, 100		
	Data save	100 data per file (up to 1000 file)		
	Data logging	Logging intervals: 0.5, 1, 2, 5, 10 s., number of data: 10 to 36000		
Optical connector	SC, FC, 2.5 mm diameter ferrule, 1.25 mm diameter ferrule			

Optical power checker (/PC option)

Items	Specification
Wavelength settings	1310/1490/1550/1625/1650 nm
Power range*2	-50 to -5 dBm
Measurement accuracy*3	±0.5 dB
Optical input port	OTDR port*4

Visible light source (/VLS option)

Items	Specification
Optical output power	-3 dBm or more (peak)
Wavelength	650 ±20 nm
Modulation mode	CW/CHOP (Approx. 2 Hz)
Optical output connector	2.5 mm diameter ferrule type
Laser class	Class 3R

*1 CW, 1310 ±2 nm (Standard, High Power, 1550 ±2 nm (PON at 1550 nm), spectral width: 10 nm or less, input power: 100 μW (-10 dBm), SM (ITU-T G.652), FC/PC connector, Wavelength settings: measured wavelength ±0.5 nm, excluding a secular change of equipment (add 1% a year after calibration)

*2 CW, maximum input power: 0 dBm (1 mW)

*3 CW, 1310 nm, -10 dBm, SM (ITU-T G.652)

*4 Not applicable to port 2

Accessories for AQ7290



Soft carrying case 739860



Battery pack 739883



Shoulder belt B8070CY



Optical switch box AQ3550

Accessories for OTDR port

Universal adapter

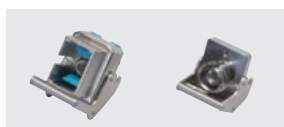

SU2005A-SCC SU2005A-FCC

LCSC Conversion adapter



735483

Accessories for OPM port

Universal adapter

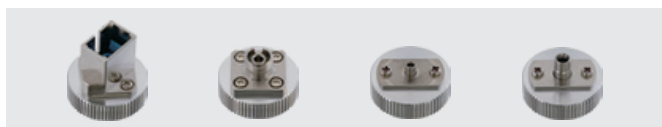

735480-SCC 735480-FCC 735481-LMC (1.25 diameter) 735481-SFC (2.5 diameter)

Dimensions

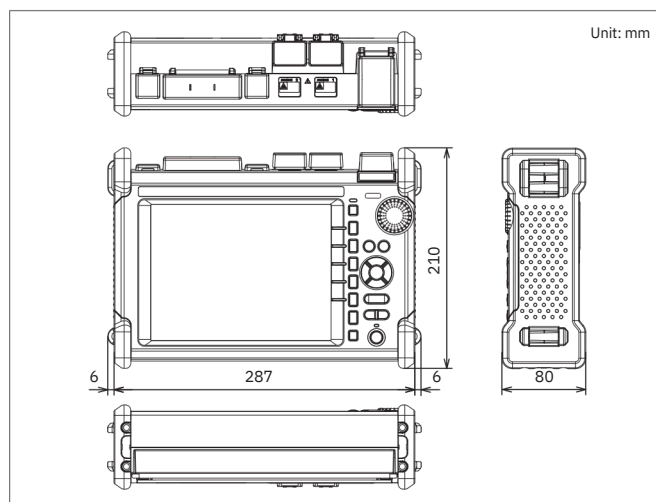

Model and suffix code

OTDR

Models	Suffix	Descriptions	
AQ7292A		2WL 1310/1550 nm 39/37 dB	
AQ7293A		2WL 1310/1550 nm 43/42 dB	
AQ7294A		2WL 1310/1550 nm 47/47 dB	
AQ7293F		3WL 1310/1550, 1650 nm 43/42, 40 dB	
AQ7293H		3WL 1310/1550/1625 nm 43/42/40 dB	
AQ7294H		3WL 1310/1550/1625 nm 47/47/45 dB	
Language	-HE	English (Multi-language)	
	-HM	Chinese	
	-HC	Chinese/English	
	-HK	Korean/English	
	-HR	Russian/English	
Optical connector	-USC	Universal adapter (SC)	
	-UFC	Universal adapter (FC)	
	-ASC	Universal adapter (Sc Angled-PC)	
	-NUA	No universal adapter	
	/SPM	Standard optical power meter	
Option	Optical power meter (OPM)	/HPM	High power optical power meter
		/PC	Power checker*1
		/VLS	Visible light source
		/MNT	Monitoring function
		/FST	Fiber surface test function
		/LAN	Ether net
		/VLS	Visible light source
		/SB	Shoulder belt

Standard accessories: Connecting cable for USB power adapter, Battery pack, hand belt, startup guide

*1 Not applicable to the port 2 of AQ7293F

Additional option license

Descriptions	Suffix
Additional option license for AQ7290	
Monitoring function	/MNT
Fiber surface test function	/FST

Notice

- Before operating the product, read the user's manual thoroughly for proper and safe operation.
- Any company names and product names mentioned in this document are trade names, trademarks or registered trademarks of their respective companies.
- "Typical" or "Typ." in this document means "Typical value", which is for reference, not guaranteed specification.
- Three-year warranty is for the OTDR mainframe, OTDR units, and OPM/VLS modules.

Yokogawa's approach to preserving the global environment

- Yokogawa's electrical products are developed and produced in facilities that have received ISO14001 approval.
- In order to protect the global environment, Yokogawa's electrical products are designed in accordance with Yokogawa's Environmentally Friendly Product Design Guidelines and Product Design Assessment Criteria.

Accessories (Sold separately)

Models	Suffix	Descriptions
SU2005A-SCC	Universal adapter (SC)	for OTDR port (Shared by -USC & -ASC)
SU2005A-FCC	Universal adapter (FC)	for OTDR port
735480-SCC	Universal adapter (SC)	for OPM port*2
735480-FCC	Universal adapter (FC)	for OPM port*2
735481-LMC	Ferrule adapter (1.25 dia)	for OPM port*2
735481-SFC	Ferrule adapter (2.5 dia)	for OPM port*2
735483	LCSC conversion adapter	
739860	Soft carrying case	
739883	Battery pack	
B8070CY	Shoulder belt	
AQ3550-112-SA-SCC	AQ3550 Optical switch box	for SM

*2 All universal adapters of OPM module are Angled-PC compatible.

Application software

Models	Suffix	Descriptions
AQ7933		AQ7933 Emulation software
	-SP01	Download version (1-license)
	-SC01	Package version (1-license)

YOKOGAWA

YOKOGAWA TEST & MEASUREMENT CORPORATION

Global Sales Dept. /E-mail: tm@cs.jp.yokogawa.com

YOKOGAWA CORPORATION OF AMERICA

YOKOGAWA EUROPE B.V.

YOKOGAWA TEST & MEASUREMENT (SHANGHAI) CO., LTD.

YOKOGAWA ELECTRIC KOREA CO., LTD.

YOKOGAWA ENGINEERING ASIA PTE. LTD.

YOKOGAWA INDIA LTD.

YOKOGAWA ELECTRIC CIS LTD.

YOKOGAWA AMERICA DO SUL LTDA.

YOKOGAWA MIDDLE EAST & AFRICA B.S.C(c)

<https://tmi.yokogawa.com/us/>

<https://tmi.yokogawa.com/eu/>

<https://tmi.yokogawa.com/cn/>

<https://tmi.yokogawa.com/kr/>

<https://tmi.yokogawa.com/sg/>

<https://tmi.yokogawa.com/in/>

<https://tmi.yokogawa.com/ru/>

<https://tmi.yokogawa.com/br/>

<https://tmi.yokogawa.com/bh/>

<https://tmi.yokogawa.com/>

YMI-N-MI-M-E03

The contents are as of February 2025. Subject to change without notice.

Copyright © 2025, Yokogawa Test & Measurement Corporation
[Ed: 01/b] Printed in Japan, 502(KP)